

ORIGINAL RESEARCH

Non-invasive blood pressure measurement algorithm using neural networks

Han Chun Lin, Andrew Lowe, Ahmed M Al-Jumaily*

Auckland University of Technology, Institute of Biomedical technologies, Auckland, New Zealand

Received: March 31, 2014

Accepted: May 14, 2014

Online Published: May 22, 2014

DOI: 10.5430/air.v3n2p16

URL: <http://dx.doi.org/10.5430/air.v3n2p16>

Abstract

The oscillometric method is the most commonly used automatic monitoring blood pressure measurement method nowadays. Height-based and Slope-based criteria are the two general means used to determine the systolic and diastolic pressures; however they are disputed for their accuracy. Thus, the auscultatory method continues to be the gold-standard for these measurements. In this paper a newly developed cuff with piezofilm sensors and a pressure sensor to collect signals from the brachial artery is investigated. Using Neural Networks to classify the acquired pressure signals in various regions, an algorithm is developed and implemented in signal processing and heart beat/heart rate detection software. The algorithm is tested on 258 measurements from 86 subjects and shows good conformance to the standards set out by the Association for the Advancement of Medical Instrumentation and British Hypertension Society grade A criteria.

Key Words: Neural network, Algorithm, Blood pressure

1 Introduction

Blood pressure (BP) is an essential parameter in professional medical care especially for management of certain illnesses, blood hypertension classification and patient monitoring. BP measurement methods can be classified into two groups, invasive (direct) and non-invasive (indirect). The first involves inserting a catheter into the vascular system, which brings high risks of embolism, arrhythmia, heart attack and a certain percent of mortality;^[1] however, the second is safer, easier to use, and can be utilized in most situations.^[2,3] This research focuses on the second method.

In 1896 the Italian paediatrician Scipione Riva-Rocci invented the air cuff sphygmomanometer measurement method.^[4] Mercury sphygmomanometers soon became the gold-standard for non-invasive blood pressure (NIBP) measurement. Environmental concern about mercury contamination has highlighted the need to find a replacement for traditional mercury sphygmomanometers. Aneroid sphygmomanometers are an option for manual sphygmomanometry but aneroid devices have to be frequently calibrated.

Although there are many different NIBP measurement devices commercially available, clinical use devices, which are expected to have higher accuracy, are very expensive and in certain sub-groups of populations, such as pregnant women, these devices remain inaccurate. A clinical review^[5] showed that of 23 automated BP measurement devices validated according to the British Hypertension Society (BHS)^[6] and Association for the Advancement of Medical Instrumentation (AAMI)^[7] standard protocols, five of them were recommended for clinical use and only one (Omron HEM-772C), when tested on elderly subjects, achieved an A/A grading according to the BHS protocol.

The oscillometric method is based on the principle that the pulsatile blood flow through an artery creates arterial wall oscillations which are transmitted through the soft tissue to the occluding cuff where they are detected as cuff pressure oscillations. As the occluding cuff pressure is gradually reduced from above systolic (SP) to below diastolic (DP), the SP, DP and the mean pressure (MP) can be estimated.^[2,8] There is a general agreement that MP is determined from the cuff pressure at which maximum oscillation amplitude

*Correspondence: Ahmed M Al-Jumaily; Email: ahmed.al-jumaily@aut.ac.nz; Address: Institute of Biomedical Technologies, Auckland University of Technology, Private Bag 92006, WD301B Auckland, New Zealand.

is observed. Height-based and Slope-based criteria are the two general means used to determine the SP and DP values; however, the accuracy of these two criteria are regularly disputed.

This paper describes an investigation into the synthesis of various height- and slope-based metrics by pattern recognition methods to achieve the accurate determination of blood pressure by the oscillometric method.

2 Experimental setup

2.1 Apparatus

Blood pressure was measured using an occlusive upper-arm blood pressure cuff. Three different size cuffs (small, medium and large) were used, as appropriate to the subject. A DT4 piezoelectric sensor (Measurement Specialties, VA, USA) was placed on the outside wall of each cuff in the circumferential direction as shown in Figure 1. One contact of the DT4 sensor was connected to ground. The other contact was connected to an operational amplifier. The cuff design has two air hoses protruding from the bladder. One hose was connected to a Medisave aneroid sphygmomanometer while the second was connected to a Welch Allyn® NIBP module which was used for automatic inflation and deflation of the cuff. The NIBP module was also connected to an ADP1 semiconductor pressure sensor (Matsuchita Electrical Works Ltd, Japan) via a tee-junction. The ADP1 was powered using a 5V reference from a data acquisition card, DAQCard-AI-16XE-50 (National Instruments, TX, USA), in differential input mode, and both the output voltage corresponding to pressure and the voltage across the DT4 sensor were measured using a differential analogue input on the DAQCard. The schematic setup of the apparatus is illustrated in Figure 2. A LabView v6.1 Virtual Instrument (National Instruments, TX, USA), was created for data recording at a sampling rate of 250 Hz. Analysis of saved data was performed in MATLAB R2012b (The Mathworks, MA, USA).

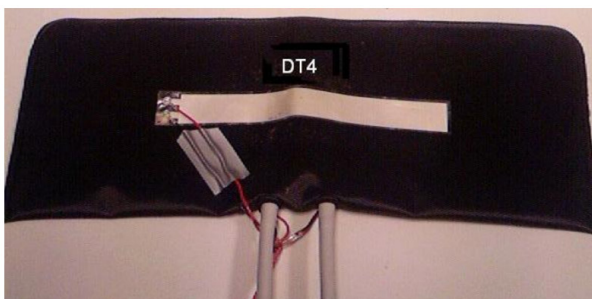

Figure 1: Photo of cuff outside wall showing DT4 piezoelectric sensor element

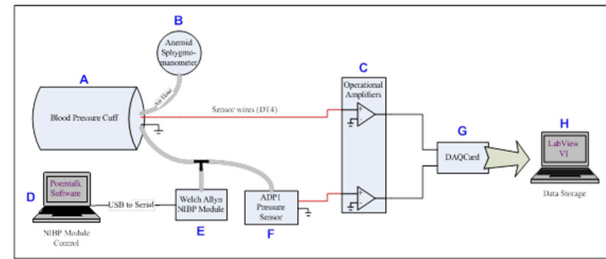

Figure 2: Schematic setup of apparatus

The bell mode side of a 3MTM Littmann® dual-head teaching stethoscope was used to measure auscultatory blood pressure. This stethoscope was used to allow two observers to listen simultaneously.

2.2 Cuff pressure calibration

The voltage output from the ADP1 pressure transducer was calibrated against the aneroid sphygmomanometer over the range 20-250 mmHg and the ADP1 was found to have a linear characteristic between 0.5 to 3.5 V output. Calibration was checked at 10 mmHg intervals between 250 mmHg and 20 mmHg. Regular calibration was performed throughout the data collection period to verify the stability and the accuracy of the output signal.

2.3 Data collection

Application for ethical approval was submitted and approved by the Auckland University of Technology Ethics Committee (AUTEK-06/126). All participants were required to sign a written consent form. Only healthy subjects aged 16 and above were invited for the study. 85 subjects were enrolled and a set of three consecutive measurements was obtained by two observers using the auscultatory method on cuff deflation, with cuff inflation and deflation automatically controlled by the NIBP module. Measurements were repeated if either the SP or DP readings from both observers differed by more than ± 5 mmHg. For those subjects who had weak Korotkoff sounds, irregular heart rate or other problems found during the measurement process, the recorded data was not used in this research. Data acquisition occurred simultaneously with auscultation.

2.4 Algorithm development

Figure 3 shows typical changes in DT4 and cuff pressure sensor signals as cuff pressure is decreased from the supra-systolic region to the sub-diastolic region. Automatic signal processing algorithms were employed to quantify changes in the shape of each pulse in the DT4 signal through cuff deflation. Pattern recognition using artificial neural networks (ANN) was applied to determine SP and DP. Implementations are described in the next section.

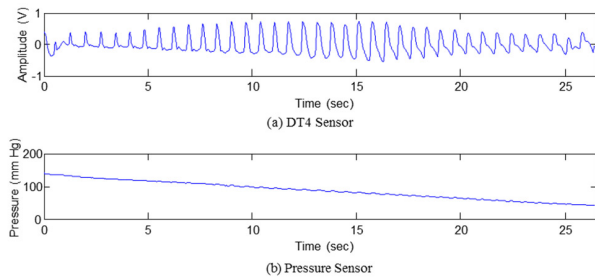

Figure 3: Typical changes in DT4 (a) and cuff pressure (b) sensor signals during cuff deflation

3 Signal processing

The automatic blood pressure determination algorithm proceeded as follows: 1) The raw cuff pressure data was filtered using a minimum mean-squared error finite impulse response, low pass filter with corner at 20 Hz and order 2000. 2) The cuff pressure and DT4 time series were segmented at each end-diastolic point, so that each segment corresponded to one heartbeat. 3) Any baseline drift was removed from the DT4 signal, to create a waveform (baselined heartbeat, BHB) oscillating from zero. 4) For each BHB, a set of features were calculated and associated with the cuff pressure at the start of the heartbeat. 5) A first artificial neural network (ANN) classifier was trained to classify each BHB, based on presented features, as above SP, below DP, or between SP and DP. The ANN returned a value between 0 and 1 for each of the three outputs, with 1 representing a positive classification. 6) A second ANN classified the outputs of the first ANN for three consecutive beats, generating a single output indicating a pressure between SP and DP. For a given measurement (that is, a sequence of heartbeats and corresponding ANN outputs) the output of the second ANN could be fitted by increasing and decreasing sigmoid functions with cuff pressure as the abscissa and the classifier output as ordinate. The cuff pressure at which the sigmoid crossed a value of 0.5 was deemed to be the measured SP or DP, for increasing and decreasing sigmoid functions respectively.

4 ANN classification

4.1 Heart beat classification ANN

Piezo-sensor signals corresponding to each HB were determined as described in section 3, above. Twenty-one features were extracted from each BHB in both frequency and time domains. The extracted features were used as the input of the first ANN.

To calculate time domain features, each individual HB was normalized as a proportion of the oscillometric envelope. The upper and lower bounds of the envelope were piecewise polynomial (spline) interpolations through the peaks and troughs (respectively) of each HB. Features for each HB extracted in the time domain were:

- Maximum envelope amplitude (1 feature)
- Sum of amplitude differences of all turning points in the HB (1 feature)
- Area under each time domain signal (1 feature)
- Number of maxima in each normalized HB over thresholds 0.1, 0.3, 0.5, 0.7 (4 features)
- Maximum increasing and decreasing rates of change, calculated by taking a difference between any trough and succeeding peak (or peak and succeeding trough) and dividing by the time between the trough and peak (2 features)
- Maximum increasing and decreasing gradient, calculated by taking the difference between any two samples and dividing by the sampling period (2 features)

These time domain features are explained further in Figure 4.

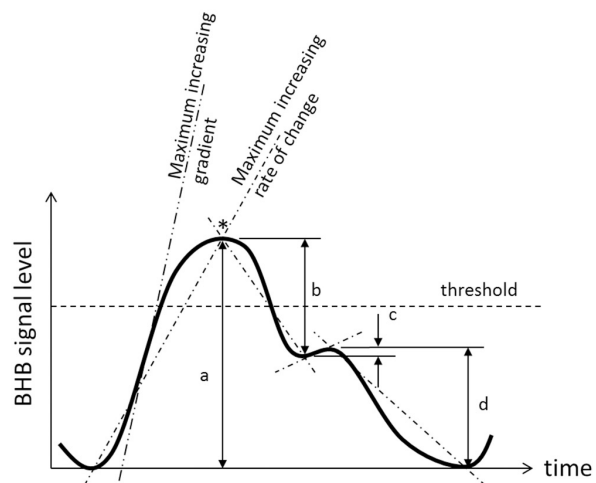

Figure 4: Time domain signal features. * indicates a maximum above the threshold. Maximum envelope amplitude is given by a. The sum of amplitude differences between turning points is given by a+b+c+d

To calculate frequency domain features, each individual normalized HB was windowed using a Hanning window, where the window length was about 70%-80% of the mean beat rate from the start of the beat. Windowing was applied to derive a pseudo-periodic signal. Features then extracted in the frequency domain were:

- Average magnitude of frequency components in the frequency ranges 5-35Hz, 10-35Hz, 15-35Hz, 20-35Hz and 25-35Hz (5 features)
- Average of the power spectral density in the same frequency ranges (5 features)

A total of 21 feature values, 10 and 11 values from the frequency and time domains, respectively, were extracted from each HB for off-line ANN training and testing purpose.

Feature extraction was followed by rescaling relative to the same feature for all BHB in the same measurement. All features were approximately within one order of magnitude of each other as calculated, so further rescaling was not per-

formed. The resulting sets of scaled features represented the input patterns to the first ANN.

Target values for ANN training were determined based on the cuff pressure corresponding to the start of each BHB.

For the first ANN, a topology with a single hidden layer was chosen and the number of neurons in the hidden layer was selected from 1 to 30 in the design process. Hidden layer nodes utilised a tan-sigmoid transfer function. Output layer nodes utilised a log-sigmoid transfer function. Figure 5(a) is a schematic of the first ANN. Weights were initialised using a pseudo-random seed that was held constant for each topology (number of hidden layer nodes) to allow comparability.^[9] Results are presented for an ANN topology with 3 hidden layer neurons.

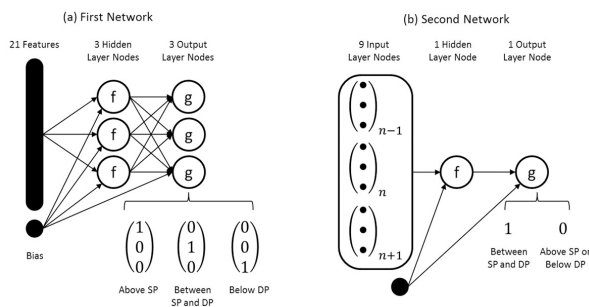

Figure 5: Heart beat classification network (a) and blood pressure determination network (b). Function f is a tan-sigmoid, function g is log-sigmoid

4.2 Blood pressure determination ANN

The three element output vectors of the first ANN were used as the input to the second ANN. Output vectors from three consecutive beats formed the nine-element input vector for the second ANN, as shown in Figure 5. From the designed target all HB at cuff pressure between SP and DP should have an output of 1, otherwise 0.

The second ANN had a single hidden layer neuron with tan-sigmoid transfer function. A log-sigmoid transfer function was used to calculate the output. Figure 5(b) shows the second ANN.

Blood pressures were selected from the output vector of the 2nd ANN. Every output contained values between 0 and 1. Hard classification was performed by rounding ANN outputs.^[10] To increase robustness in the presence of large pulses caused by body motion the first HB of the first three consecutive HB with output of 1s was selected for SP. The last HB of the last three consecutive HB with output of 1s was selected for DP. An alternative selection method tested was to select one HB higher than the output as determined

by the process just described. The results were compared to the standard protocols

4.3 Design and training of the NN

An ANN needs to go through the training process and adjust weights until the network output matches the target. There are four steps in the training process.^[9] 1) Assemble the training data – the feature inputs extracted from each HB. 2) Design the network object – design and initialise the neural network. 3) Train the network – modify weights. 4) Simulate the network – compare the output and target values by applying new input data. Both ANN were trained using the BFGS Quasi-Newton method. Training was terminated on reaching a performance error goal of 0.1%, or ratio values of 0.1. The error rate for the ANN was determined by the proportion of correctly classified HB across the entire data set. A good ANN should have both training and testing errors as low as possible and as close as possible.

5 Algorithm validation

5.1 Initial design and validation

Initial validation was performed using data from 76 subjects, for which there were 3 measurements each. 2/3 of the aggregated measurements were randomized to the testing data set. Validation was performed on the remaining 76 measurements. The results are presented in Bland and Altman plots and a table to show the mean, SD and the percentage of the measurement error. The validation result which Passed/Failed the AAMI protocol and the grades obtained according to the BHS protocol were also included in the table.

After initial design and validation, a first ANN structure with 3 hidden layer neurons was selected as shown in Figure 5. Referring to Tables 1 and 2, “Net 1” is the BP selection result from the 1st ANN; “Net 2_1” is the BP selection result from the 2nd ANN with original BP selection method; “Net 2_2” is the BP selection result from 2nd ANN with one HB shifting method and “Net 2_3” is the BP selection result from 2nd ANN with one HB shifting method on the SP selection and original selection on the DP selection.

The training and testing errors from 1st ANN were 13.36% and 14.99%, respectively. The training and testing errors from 2nd ANN were 8.93% and 8.18%, respectively. Table 1 summarises the ANN results compared to the AAMI and BHS standard protocols. Figure 6 shows the Bland Altman plot of the BP estimation to compare ANN classification results from Net 2_3 and Auscultatory algorithm results. The target and the output values simulated by both 1st and 2nd ANN are shown in Figure 7.

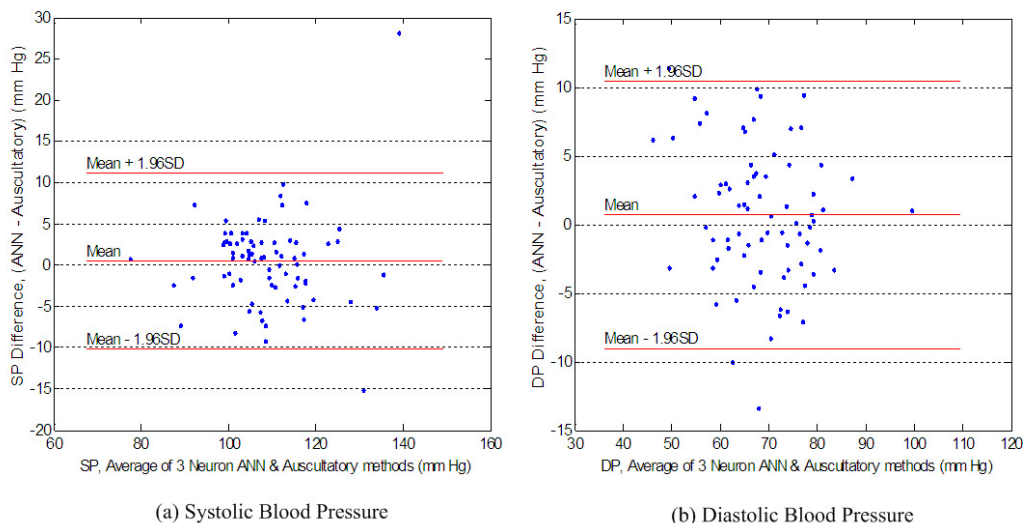

Figure 6: Bland and Altman plot of 21 input data sets with 3 hidden layer neurons in the ANN and Auscultatory result comparison from 76 testing measurements

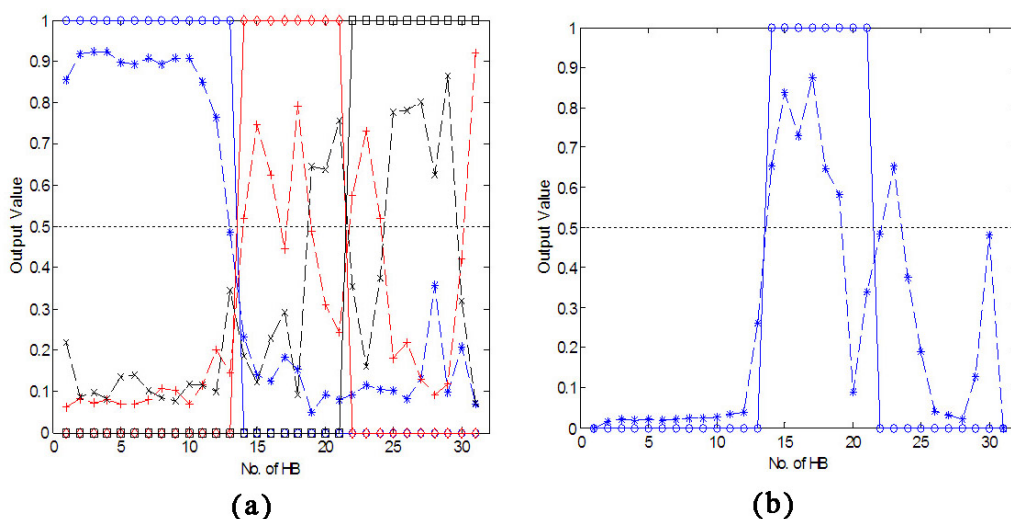

Figure 7: 1st and 2nd ANNs simulated output for subject 45, recording 3, by using 21 input data sets.

Table 1: Results from 21 input data sets compared to the standard protocols by using different BP selection methods.

21 Inputs	Systolic Pressure Measurement Error					Diastolic Pressure Measurement Error					Standard (SP / DP)	
	mean	SD	≤±5	≤±10	≤±15	mean	SD	≤±5	≤±10	≤±15	AAMI	BHS
Net											Pass/Fail	Grades
1	-3.15	6.01	63.16	90.79	94.74	-0.53	5.53	68.42	96.05	98.68	P/P	B/A
2_1	-2.97	5.45	65.79	92.11	97.37	0.69	4.96	68.42	96.05	100	P/P	A/A
2_2	0.46	5.46	73.68	97.37	97.37	3.77	5.05	56.58	86.84	100	P/P	A/B
2_3	0.46	5.46	73.68	97.37	97.37	0.69	4.96	68.42	96.05	100	P/P	A/A

5.2 Final validation

New measured data from 10 additional subjects, involving 30 measurements, was collected to add up to 86 subjects, involving 258 measurements, for the algorithm final validation. The finalised ANNs were kept similar without using the new measured data for further training. Table 2 shows

the ANN results from the total of 258 measurements and compared to the AAMI and BHS standard protocols. Figure 8 shows the Bland Altman plot of the BP estimation to compare ANN classification results from Net 2_3 and Auscultatory algorithm results.

Table 2: Results from 21 input data sets compared to the standard protocols by using different BP selection methods on 86 subjects, 258 measurements

21 Inputs	Systolic Pressure					Diastolic Pressure					Standard (SP / DP)	
	Measurement		Absolute difference (%)			Measurement		Absolute difference (%)			AAMI	BHS
Net	mean	SD	$\leq \pm 5$	$\leq \pm 10$	$\leq \pm 15$	mean	SD	$\leq \pm 5$	$\leq \pm 10$	$\leq \pm 15$	Pass/Fail	Grades
1	-3.17	8.33	64.73	91.09	96.51	0.12	7.30	66.67	89.15	96.90	F/P	A/A
2_1	-2.06	5.21	72.48	92.25	98.45	1.77	6.17	63.95	89.53	96.12	P/P	A/A
2_2	1.44	5.27	71.32	96.51	98.06	5.02	6.33	45.35	81.40	94.96	P/F	A/C
2_3	1.44	5.27	71.32	96.51	98.06	1.77	6.17	63.95	89.53	96.12	P/P	A/A

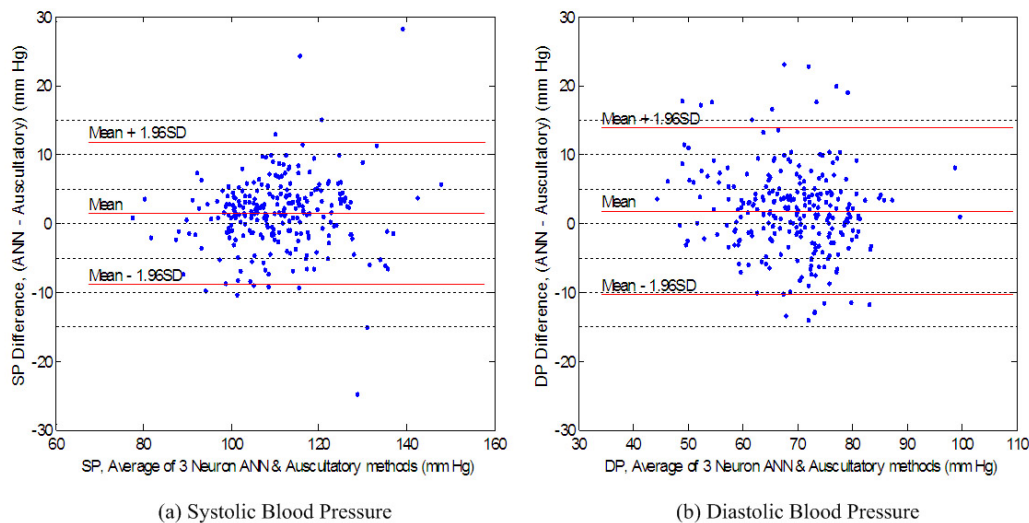

Figure 8: Bland Altman plot of the BP estimation to compare ANN classification results from Net 2_3 and Auscultatory algorithm results

6 Discussion

6.1 Data collection

A total of 94 subjects participated in this research. 8 were excluded as stated: 2 did not contribute 3 data sets within the difference of ± 5 mmHg between observers, in 1 case the Korotkoff sounds heard fell below 20 mmHg, 1 had an irregular HR, 2 were under medication and another subject had had heart valve surgery in the past. One withdrew due to the discomfort of cuff pressure. The AAMI standard recommended that when using the auscultatory monitoring method for comparison, at least 10% of SP and DP values should fall outside the range from 100 to 160 mmHg and 60 to 100 mmHg respectively. 10% of the total subjects should have an arm size above 35 cm and below 25 cm in circum-

ference. None of the 86 subjects had SP greater than 160 mmHg and DP greater than 100 mmHg. 14.7% of subjects had SP less than 100 mmHg and 17.8% of subjects had DP less than 60 mmHg. In this research, there was only 1 subject (1.2%) that had an arm size greater than 35 cm and 11 subjects (12.8%) had an arm size less than 25 cm. None of the subjects had hypertension. Not many people with an arm size greater than 35 cm were available and some of them did not want to participate in this research. Therefore, this requirement was not met.

The AAMI standard recommended that for the auscultatory measurement, two trained observers should have 100% of simultaneous measurements within a difference of 10 mmHg, and 90% or more within 5 mmHg. In order to

enhance the credibility of the data since the two observers in this research were not professionally trained, the difference agreement between observers was tightened to 100% of measurements within 5 mmHg. At the end of this research, a total of 294 measurements had been taken from 86 subjects. A total of 36 measurements had a difference of more than 5 mmHg between observers and the rest of the 258 measurements were used for testing the final algorithm.

6.2 Signal processing

The algorithm tries to find the start of each HB, corresponding to the end-diastolic point. Artefacts on the DT4 sensor signal, possibly due to movement or even ectopic beats mean that the end-diastolic point is not always correctly identified. In this case, the following pulse may be very small, or decrease below the baseline, causing non-comparable features with correctly identified beats. This would affect either the network training, or validation. As a partial mitigation against the effects of artefacts, each HB was windowed by using the Hanning window to reduce the start and end of each HB to zero. Although a band-pass filter and FFT functions were also evaluated for this purpose, the Hanning window produced the best result for the requirement of this research.

6.3 Heart beat / Rate determination

HBs were easily detected by applying a second order Butterworth low pass filter with a corner frequency at 1.3 Hz from the first 9 subjects of measurements. When measurements increased to 76 subjects, the developed HB detection algorithm was not able to detect the HB for all cases using the same corner frequency. Therefore, variable corner frequencies from 0.5 Hz to 2 Hz were designed to perform the HB detection for all subjects. This variation worked well for all healthy subjects involved in this research. However, it is understood that measurements from diseased subjects such as bradycardia (slow heart) or tachycardia (rapid beating) and subjects not in a resting situation may need another automatic HB determination method.

6.4 Pressure selection

The pressure value selected for each HB was the pressure at the point on the upstroke of the oscillation signal. An example of a measured pressure signal is shown in Figure 9. The Korotkoff sounds should be heard approximately when the cuff pressure matches the BP. However, in the method used, the cuff pressure deflated continuously, except for upward oscillations induced by the BP. The upstroke of the pressure was defined as the pressure value for that HB for uniformity.

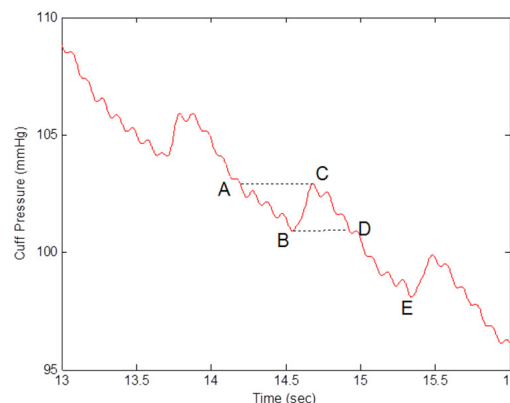

Figure 9: An example of pressure signal measured from subject 5, recording 1

6.5 Classification

Feature extraction of significant information from the measured signal data is the most difficult but crucial part of the ANN classification algorithm. It can affect the success or failure in the analysis. The selected features were chosen based on visually observed signal changes among pulses.

There were only 53 HBs used in the sub-diastolic pressure region for training and 26 HBs for testing the ANNs during the algorithm development. Since there were so few HBs in the sub-diastolic pressure region it was difficult to apply, train and validate the algorithm for DP determination. The reason for the small number of HBs in the sub-diastolic region was because the software truncated the last few seconds of measured signal due to noise in this period, which could be significant, and in some cases larger than the actual signal. Further investigation showed that the noise signals were caused by the movement of the subjects: Every time the observers noted the DP from the subject, observers would proceed to record the BP for that subject before stopping the recording. Frequently, the subjects would presume the measurement was complete and start to move their arms or clench their fists, resulting in the recorded noise. After this problem was discovered, observers were advised to record BP after completing recording to minimise the noise signals. The final algorithm therefore used the whole recorded signal without chopping any of the noise signals at the end. This made more data available in the sub-diastolic pressure region.

The outside sensor signal was selected for the analysis. This sensor gave a clear signal and a similar pattern for most of the measurements. Signals measured from the pressure sensor also contained more noise signals after filtering than the signals measured from the outside sensor.

7 Conclusion

Standard Auscultatory BP measurement procedures were performed based on the AAMI requirement. Algorithm de-

velopments were completed for signal processing, HB/HR detection and cuff pressure selection for each HB. The final algorithm used two ANNs in series to select blood pressures. This algorithm achieved a grade A for both SP and DP according to the BHS protocol. The mean differences (SD) between the observers and the developed algorithm

were 1.44 (5.27) mmHg and 1.77 (6.17) mmHg for SP and DP respectively, which also fulfilled the AAMI criteria. In conclusion, this algorithm was successfully developed and recommended for further clinical trials with the wider adult population.

References

- [1] Holejšovská P, Peroutka Z, Cengery J, editors. Non-invasive monitoring of the human blood pressure. Proceedings 16th IEEE Symposium on Computer-Based Medical Systems; 2003.
- [2] Ball-Llovera A, Del Rey R, Ruso R, Ramos J, Batista O, Niubo I, editors. An Experience in Implementing the Oscillometric Algorithm for the Non-Invasive Determination of Human Blood Pressure. Proceedings of the Annual International Conference of the IEEE Engineering in Medicine and Biology Society; 2003.
- [3] Nissilä S, Sorvisto M, Sorvoja H, Vieri-Gashi E, Myllylä R, editors. Non-invasive blood pressure measurement based on the electronic palpation method. Proceedings of the 20th Annual International Conference of the IEEE Engineering in Medicine and Biology Society; 1998.
- [4] Northrop RB. Noninvasive Instrumentation and Measurement in Medical Diagnosis. Boca Raton, Fla.: London: CRC ; Chapman & Hall; 2001.
- [5] Eoin OB, Gareth B, Gregory YHL. Blood pressure measurement. *British Medical Journal*. 2001; 322(7295): 1167-70. <http://dx.doi.org/10.1136/bmj.322.7295.1167>
- [6] O'Brien E, Petrie J, Littler W, de Swiet M, Padfield PL, Altman DG, et al. Short report: An outline of the revised British Hypertension Society protocol for the evaluation of blood pressure measuring devices. *Journal of Hypertension*. 1993; 11(6): 677-9.
- [7] Association for the Advancement of Medical Instrumentation. American National Standard. Manual, electronic or automated sphygmomanometers. 2003; ANSI/AAMI SP10: 2002
- [8] Wang J-J, Lin C-T, Liu S-H, Wen Z-C. Model-based synthetic fuzzy logic controller for indirect blood pressure measurement. *IEEE Transactions on Systems, Man and Cybernetics*. 2002; 32(3): 306-15. <http://dx.doi.org/10.1109/TSMCB.2002.999807>
- [9] Demuth H, Beale M. *Neural Network Toolbox*. Natick, MA: The MathWorks, Inc.; 2006.
- [10] Hanselman DC, Littlefield B. *Mastering MATLAB 7*. Upper Saddle River, NJ: Pearson/Prentice Hall; 2005.